

# Gearbox and Deck Assembly

## Index

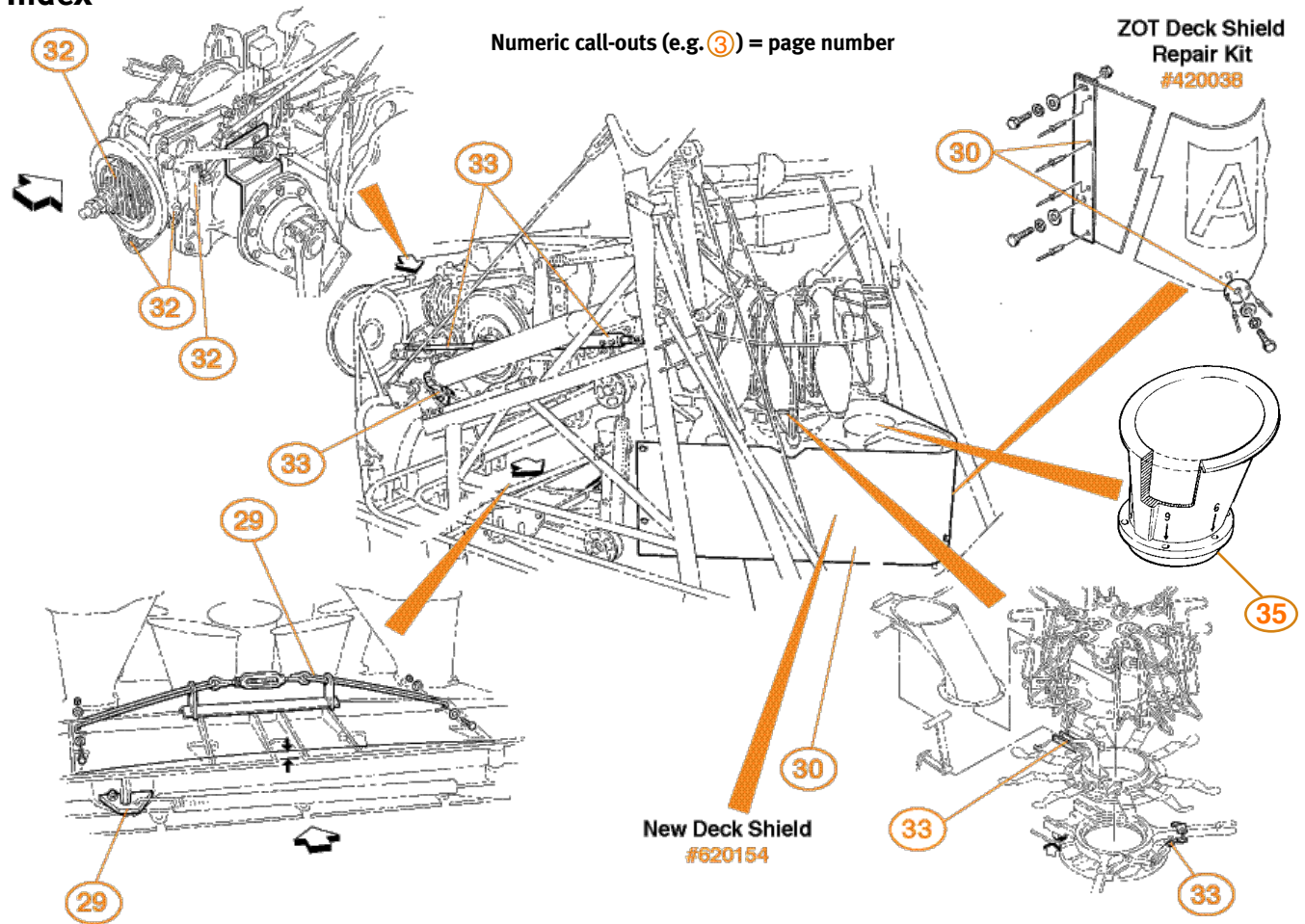

### Cam Follower Shaft Support Bracket

For 'A2', Jetback and Straight 'A' Pinsetters

# 420502

**Prevents Crisis Breakdowns:** Installing ZOT's Cam Follower Shaft Support Bracket "Today" prevents interruptions (breakdowns) during peak/league times "Tomorrow".

**ZOT's Cam Follower Shaft Support Bracket Secures the Moving Deck Cam Follower for months after the Cap Screw ("B" Bolt) has broken:** thereby preventing "Crisis Breakdown" at the least opportune time.

**Prevents Damage** to expensive 1 to 1 plates (part # 12-100207-000).

**Prolongs the Life of the Cap Screw**

**Flexible Maintenance Schedule** repairs can be scheduled when time permits, and not during peak bowling times.

**\*\* Every Brunswick Pinsetter Should Have One \*\***

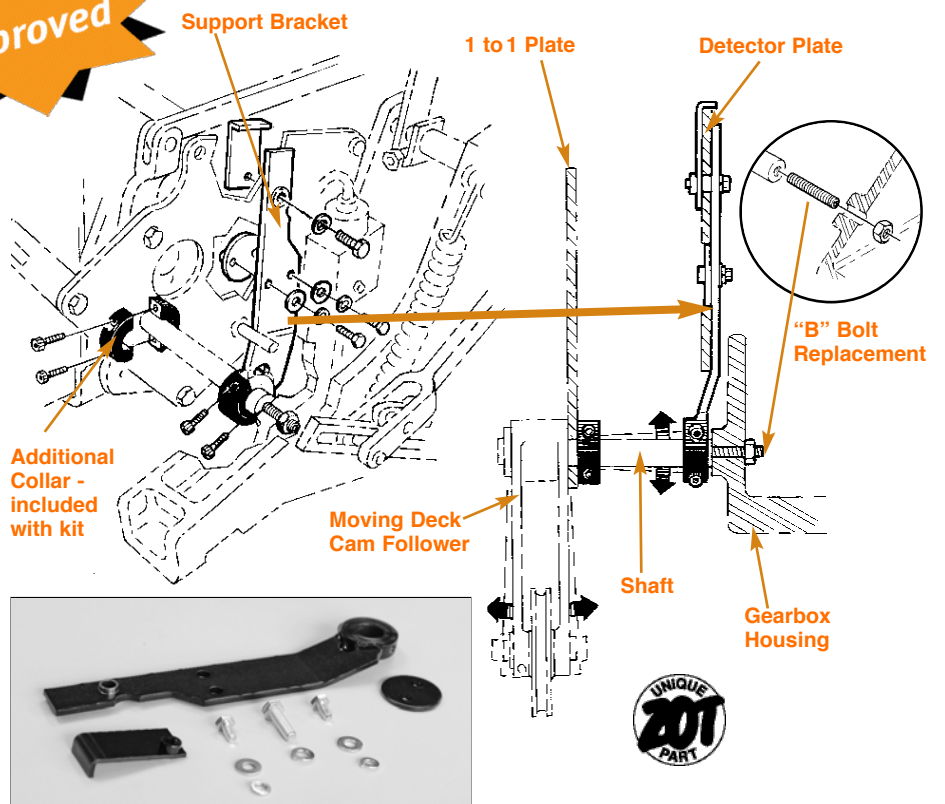

## Deck Right Deck Saver

For 'A2', Jetback and Straight 'A' Pinsetters

#420084

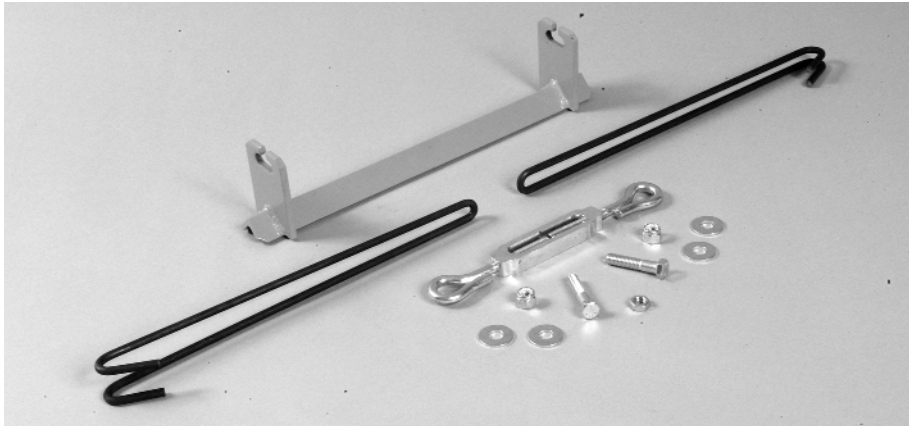

### Features and Benefits

**Reduce Respots of 5-8-9 Pins:** If the pinsetter often sweeps off the 5, 8 or 9 pins, instead of resetting them for the second ball, the deck is probably crowned. A straight edge will soon confirm this (see illustration). The ZOT Deck Right Deck Saver will permanently eliminate the crown, restoring your deck to maximum efficiency.

**Minimizes Deck Shift Problems:** If the deck does not shift freely (the tell-tale signs are rub marks, made by the pulley, on the inside of the Geneva Plates), the ZOT Deck Right Deck Saver offers a simple and permanent solution.

**No More Need for Costly Replacement...Removal -or- Welding of Decks:** And shimming deck pads to make them thicker will eventually crack them.

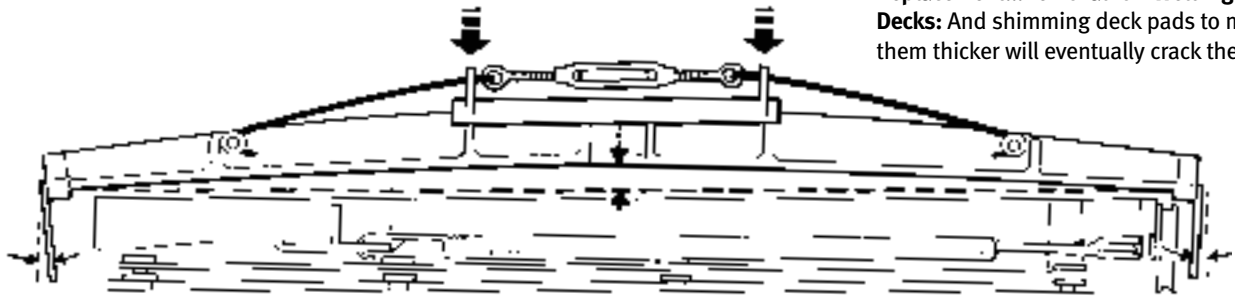

Permanent Repair

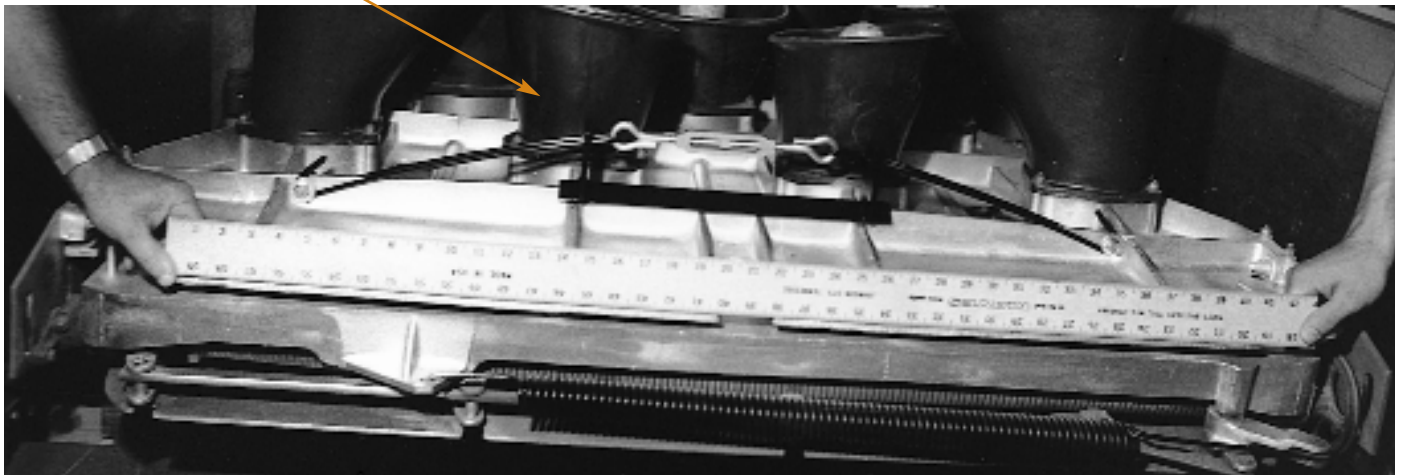

Use straight edge to check for crown on deck.

  
 Gearbox & Deck Assembly



## Scissor Spring Pivot Repair Kit

For 'A2', Jetback and Straight 'A' Pinsetters

#420285

### Features and Benefits

**No Welding Required:** Simply drill and bolt on the ZOT Scissor Spring Pivot Repair Kit for an easy and permanent repair.

**Labor and Time Saving:** A much faster repair than removing the stationary deck for rework. The ZOT Repair Kit installs in minutes.

**Prevent Crisis Breakdowns:** Why wait? If your decks are worn at the scissor spring eyelet, install ZOT's repair kit – today; and prevent league interruptions – tomorrow!

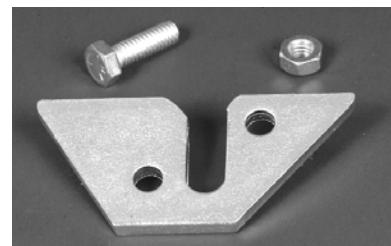
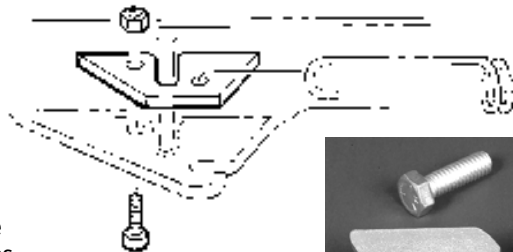

Call ZOT at 1-800-525-8116 for more details

# Gearbox and Deck Assembly

## Replacement Deck Shield

For 'A2', Jetback and Straight 'A' Pinsetters

#620154



### Features and Benefits

**If Your Deck-Shields Are Beyond Repair:** Why not replace them and upgrade the image of your center in the process.

**Standard Gray:** Direct replacement deck-shield's are of the finest quality available.

**And, For An Added Touch of Image Enhancement:** Have a local silk screener add your center name or logo to the new deck-shield before you install.

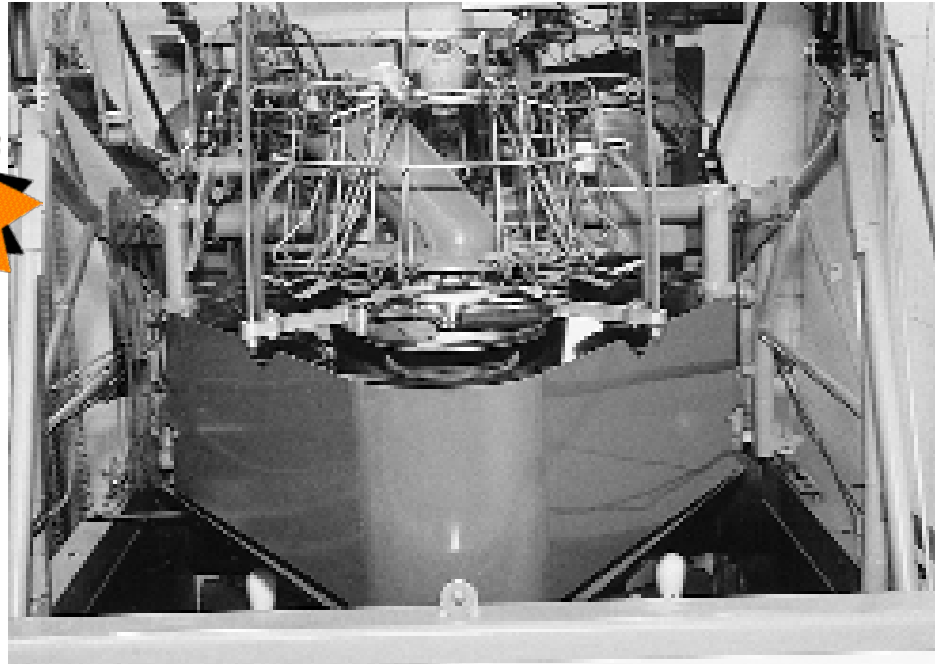

GA Gearbox & Deck Assembly

## Deck Shield Repair Kit

For 'A2', Jetback and Straight 'A' Pinsetters

#420038

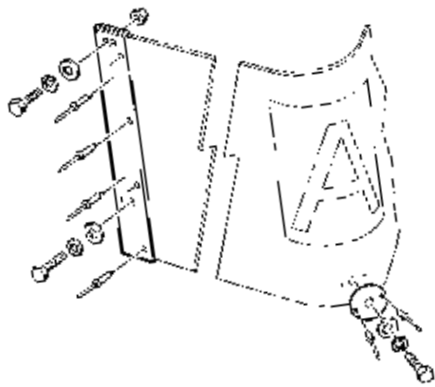

### Features and Benefits

**Big Cost Savings:** The ZOT Deck Shield Repair Kit effectively renews worn mounting slots on your existing shield: A far less expensive option than replacing the whole shield.

**Installs in Less Than 15 Minutes:** ZOT's Deck Shield Repair Kit is simple to install and will secure your deck shield – without having to remove it from the Pinsetter.



**Note:** The Complete Kit includes all mounting hardware.

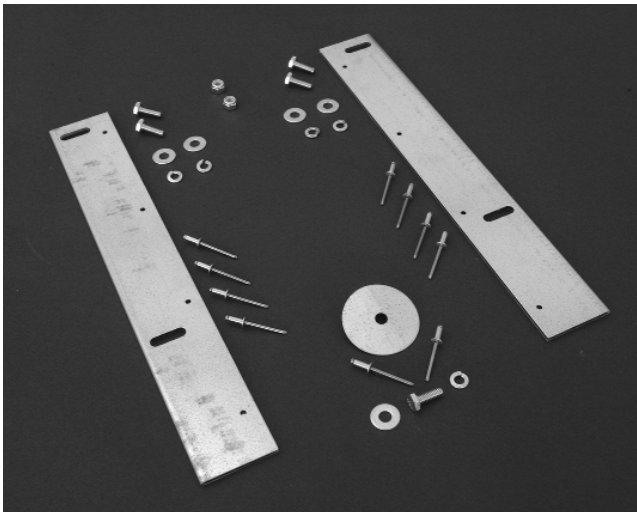

## Collapsible Rake Link

For 'A2', Jetback and Straight 'A' Pinsetters

### Features and Benefits

#### Eliminates Rake Link Replacement:

Never again will you need to replace a bent rake link. ZOT's unique Spring-Loaded Collapsible Rake Link returns to full-length – automatically; should the rake be impacted by a ball, or drop behind the deck.

**Extended Life:** ZOT's Shock Absorbing design extends the life of the rake shaft weldmet, the 4 to 1 crankshaft, the key; and other related parts.

**Prevents Crisis Breakdowns:** The ZOT Collapsible Rake Link is designed and built for no down time.

**A ZOT Original Product:** That's often imitated by other manufacturers, but never surpassed!

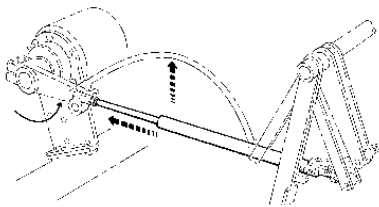

40-7/8" (1.038M) Straight End Rod  
#420009

40" (1.016M) Tapered End Rod  
#420008

**Lowest Price in the Industry!**

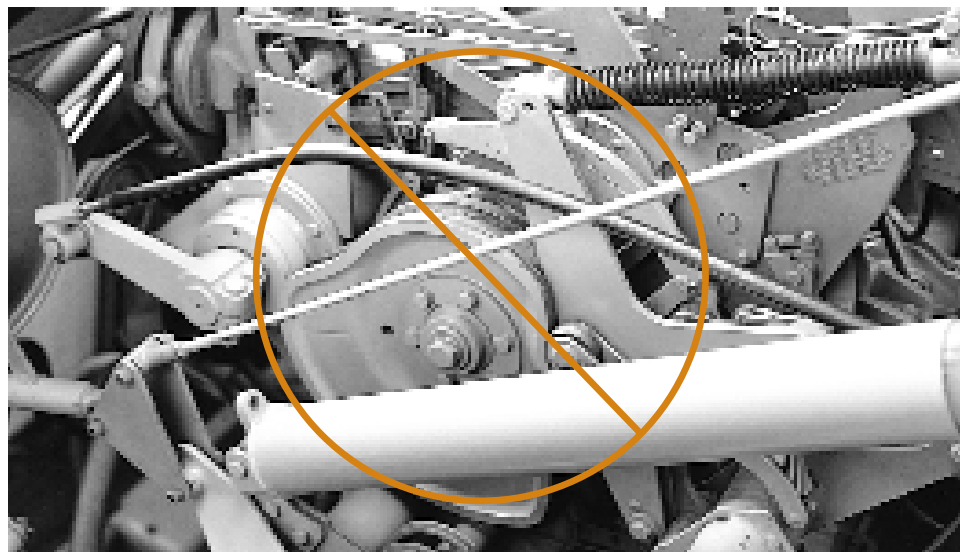

Gearbox & Deck Assembly

## Starter Bellcrank Stud

For Straight 'A' Pinsetters

#420014

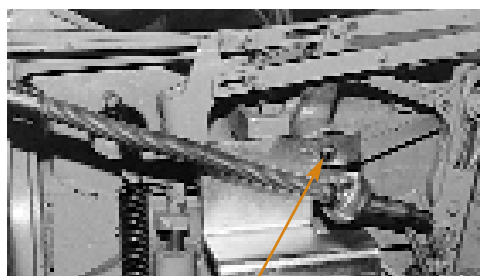
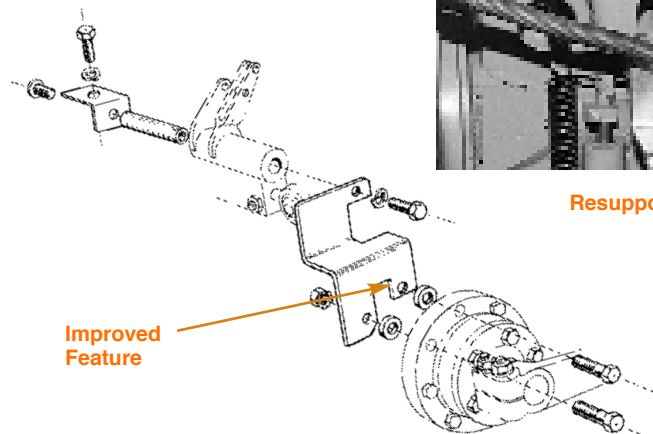

Resupport Pivot Stud



### Features and Benefits

**Eliminates Next to Impossible Drilling:** Pivot Stud broken or loose inside the gearbox housing? No problem! With the ZOT Starter Bellcrank Stud you simply leave the broken stud inside and re-support the pivot stud from the housing to the 4 to 1 flange; and eliminating almost impossible repair by drilling the gearbox housing.

**Proper Pivot Positioning Automatically:** With the ZOT Starter Bellcrank Stud there is no misalignment to damage trigger sensitivity.

**Permanent Repair:** Restores to like new working condition.



Call ZOT at 1-800-525-8116 for more details

# Gearbox and Deck Assembly

## Gearbox Clutch Bearing Assembly Kit

For 'A2', Jetback and Straight 'A' Pinsetters

#420048

**Lowest Price in the Industry!**

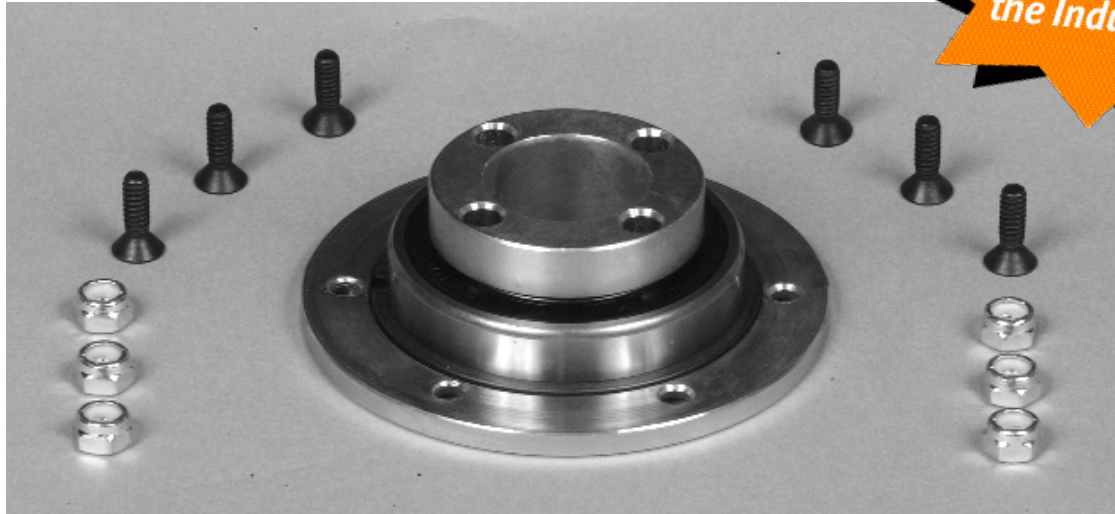

**GA**  
Gearbox & Deck  
Assembly

### Features and Benefits

**Reduced Maintenance:** ZOT's Roller Bearings are permanently lubricated for extended life and reduced maintenance.

**Compatible:** Buy the complete kit, or any of the three component parts separately. The bushing, bearing and retainer disc are all interchangeable with the original manufacturers parts.

**Extended Life:** The ZOT improved design features a 4-hole, high tensile strength Bronze, bushing which substantially minimizes wear and permits re-positioning of the dowel pin – up to 4-times – for extended life.

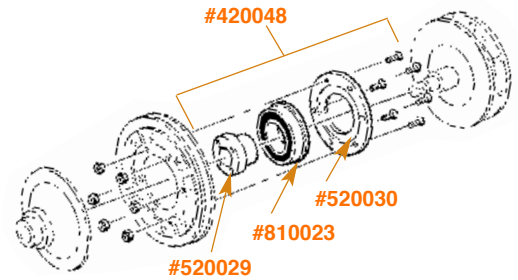

## Clutch Yoke Screw Conversion

For 'A2', Jetback and Straight 'A' Pinsetters

#420034

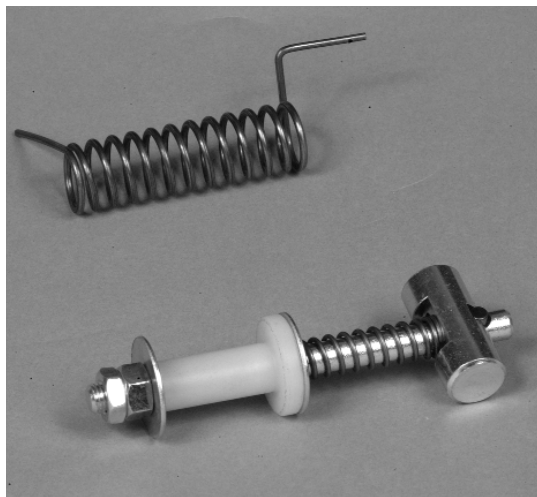

### Features and Benefits

**Big Time Saver:** The ZOT Clutch Yoke Screw Conversion will save you upwards of 28-minutes anytime you have to access the clutch spline or rotor disc. The original screw alone takes about 15

minutes to reinstall because of the long threads and difficulty in accessing and positioning the pivot pin.

**Installs in One Minute:** The unique ZOT Break-a-Way, quarter turn release, screw design installs or removes in just 1-minute; and its clutch lever support spring holds the clutch lever up – automatically.

**Reduces Wear and Tear:** Eliminates excessive clutch face wear and vibration.

**Easier Preventive Maintenance:** Reduces the number of clutch adjustments and eliminates the tedious task of realigning the yoke screw and pivot pin when reassembling. Easy access for lubrication which extends life, preventing costly replacement of clutch drive disc and related parts.

**Only Available From ZOT:** No other original manufacturer or supplier offers this unique and easy solution.

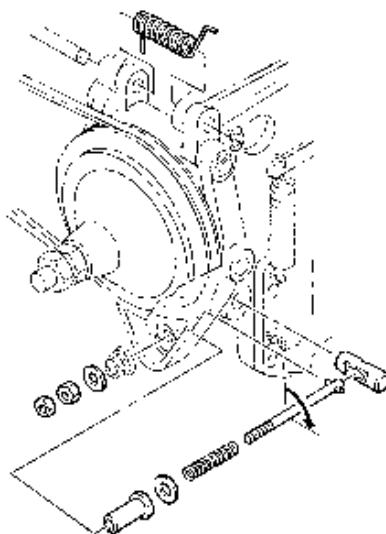

## Deck Lift Shaft Repair Kit

For 'A2', Jetback and Straight 'A' Pinsetters

#420037

### Features & Benefits

**Prevent Crisis Breakdowns:** Install the ZOT Deck Lift Shaft Repair Kit before a crisis breakdown happens during league play.

**Time Saving – No Welding:** The ZOT Repair Kit's easy drill and bolt-on application installs in just minutes; and without welding.

**Big Cost Savings:** The ZOT Repair Kit renews your deck lift shaft at only a fraction of the cost of replacing the original equipment.

**Only Available From ZOT:** No other supplier, or original manufacturer, offers this time saving, low cost, permanent repair solution.

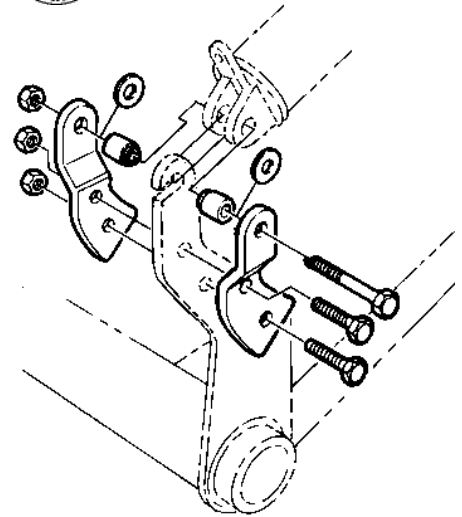

## Modified Interlock Link

For 'A2', Jetback and Straight 'A' Pinsetters

#420283

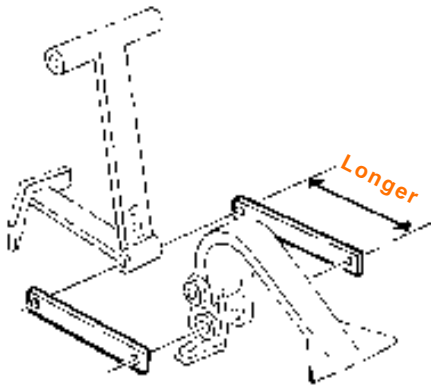

### Features & Benefits

**Modified Design Solution:** ZOT's Interlock Link is longer from center to center than the original (see illustration). Once installed on your pinsetters it repositions the Interlock Probe and prevents jams.

**Prevents 5-Pin Chute Pin Jams:** Years of use bends the pin release lever making it more difficult to trip, or activate, turret indexing.

**Note:** You will need to order two ZOT Links per machine. The ZOT Modified Interlock Link cannot be used in conjunction with an original.

## Spring Eyelet Repair Kit (Turret Release)

For 'A2', Jetback and Straight 'A' Pinsetters

#420178

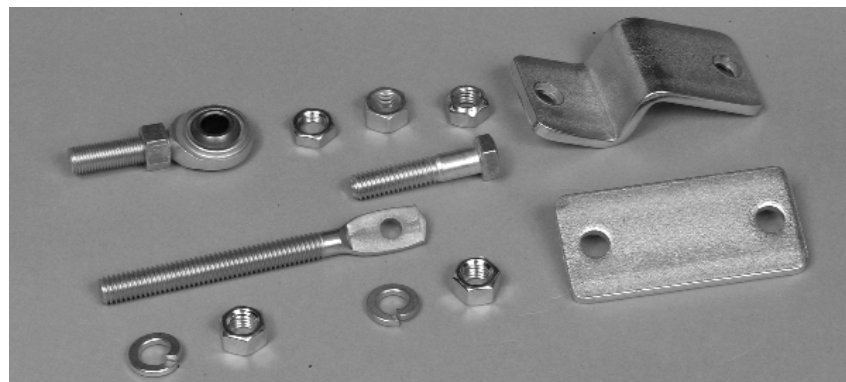

Is your spring eyelet worn out?

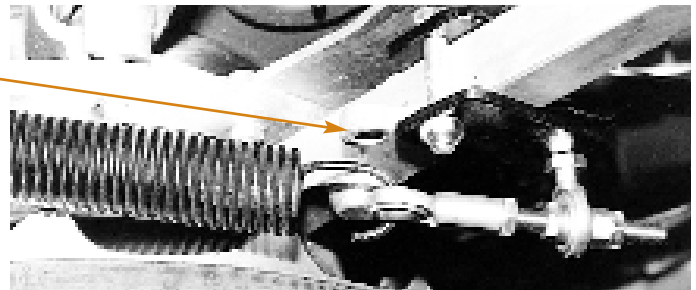

### Features & Benefits

**Replaces Worn Pivot Eyelet:** If the release spring on the turret support frame is worn out, the ZOT Spring Eyelet Repair Kit offers a simple solution.

**Installs Easily In Minutes:** And with NO drilling through the turret frame; which weakens it further: And NO disassembly.

**Eliminates Welding:** No need to remove the frame or re-weld.

**Adjustable Spring Tension:** The ZOT Spring Eyelet Repair Kit's unique design allows for greater adjustment and re-adjustment of the release spring tension.

# Gearbox and Deck Assembly

## Link Belt

For Brunswick Pinsetters

#420189 1/2" Link Belt

#420190 5/8" Link Belt

Tired of having to stock dozens of V-belts in dozens of different lengths...only to find you're missing the one you need, when you need it most? Purchases both sizes (1/2" & 5/8") of ZOT Link Belts and you'll no longer need to worry whether you have the right combinations of matching belt lengths in inventory (e.g., for motor to gear box, elevator and turret drive, etc.). ZOT's Link Belt comes in 20-foot lengths per box, and, with a simple twist of the wrist, you'll have a belt that's a perfect fit for your needs: Check these features:

### Features & Benefits

**Permanent Replacement:** Of endless and spliced V-belts.

**Eliminates the Need:** To stock extensive line of replacement belts.

**Easy Installation:** Without dismantling pinsetter drives.

**Extended Life:** Oil and Chemical resistant composite polyurethane/polyester construction.

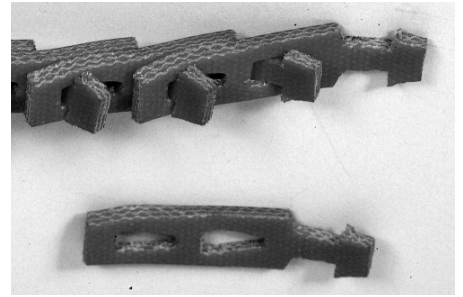
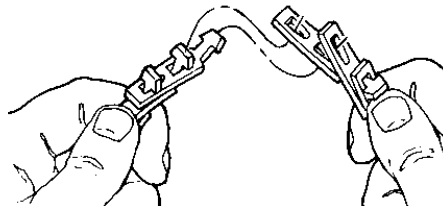

### #420189

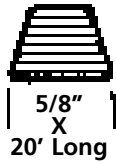

**Suitable for:**  
 All 7 Motor to Gearbox Belts (1/2")  
 All 4 Motor to Elevator Belts (1/2")  
 Long Turret Drive Belts (1/2")  
 Pit Conveyor Drive Belt (1/2")  
 Short Turret Drive Belt (1/2")  
 Cross Conveyor 'V' Drive Belt (1/2")  
 Jack Shaft Drive Belt (1/2")

### #420190



**Suitable for:**  
 Endless Ball Wheel Belt (5/8")  
 Spliced Ball Wheel Belt (5/8")  
 Pin Wheel Belt (5/8")

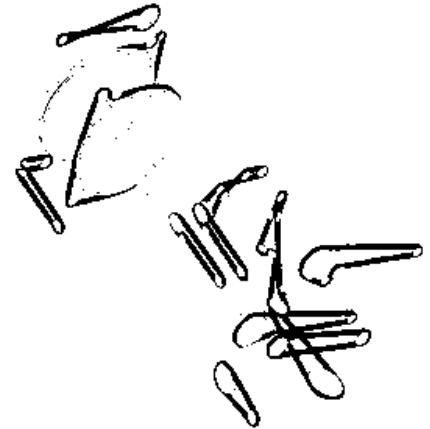

## Rubber Scissor Gripper Pad

For 'A2', Jetback and Straight 'A' Pinsetters

#820021

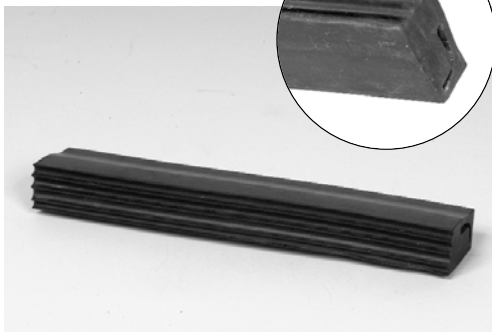

### Features & Benefits

**Neoprene Rubber:** Oil-resistant material characteristics. Install by sliding onto scissor arm.

## Snap-on Urethane Scissor Gripper Pad

For 'A2', Jetback and Straight 'A' Pinsetters

#420470

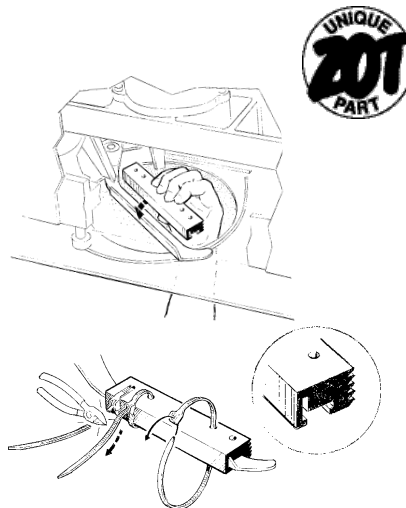

### Features & Benefits

**Urethane:** Soft non-marking oil resistant material extends service life.

**Snap-On:** Easy to install even when the scissor arm is in place on the pinsetter.

**Nylon Tie Wraps:** Secure the pad to the scissor arm with the nylon tie-wrap and the ZOT pad stays in place.

**Easy to Install:** Saves time ... Saves money.

## Urethane Deck Chutes

For 'A2', Jetback and Straight 'A' Pinsetters

“Three Styles to Fit all Ten Positions”



### Features & Benefits

**Lowest Coefficient of Friction:** ZOT's specially formulated urethane reduces friction between pins and chute and prevents pins from sticking.

**Heavy Duty Reinforced Rib:** Increasing the thickness of the material (urethane) at the stress points where chutes typically break prematurely extends the life of the ZOT product.

**Chute Identification:** All chutes are clearly marked for easy selection.

**Larger Inside Skirt Diameter:** Ensures fewer pin jams.

**Pin Positioning Etched on Combo:** An embossed number alongside each mounting hole clearly identifies which hole should be used for a specific pin position on the Combo.

**Universal 7, 10 & 1 -Pin Chute:** Reduce inventory by using ZOT's 7-10 pin chute which is easily modified for use in the 1-pin position.

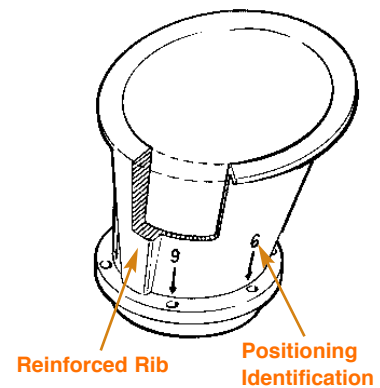

## Urethane Deck Roller

For 'A2', Jetback and Straight 'A' Pinsetters

#680010

### Features & Benefits

**Rigid and Durable:** The characteristics of the material reduces pin-bounce that causes deck or turret jams typical of harder urethane rollers.

**Urethane:** Will not mark pins and is oil resistant for longer life.

**Self Lubricating Hub:** Graphite filled hexagon insert ensures that the hub spins on the pin.

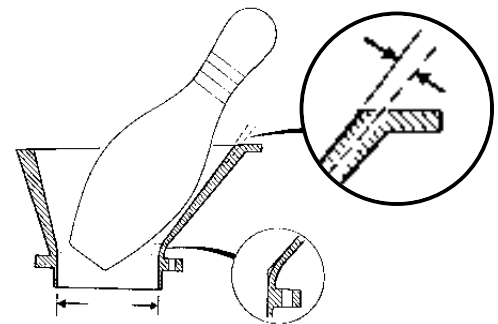
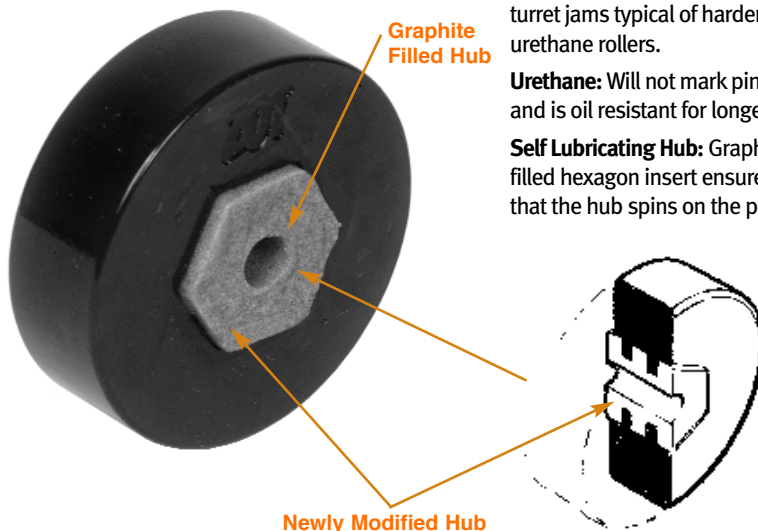

**Widest Diameter Pin Opening** available in the industry.

**Steeper Angle to Horizontal Pin Resting Position** – ensuring the pin sits more upright in the chute.

**Increased Radius or Contour** for easier pin transition from horizontal to vertical.



Call ZOT at 1-800-525-8116 for more details



# Gearbox and Deck Assembly

## Urethane Deck Pads

For 'A2', Jetback and Straight 'A' Pinsetters

Only ZOT offers a choice between standard and long-life Deck Pads

- Sold in packages of ten
- **Soft; open-cell foam:** Prevents neck checking and head scalping of pins and reduces bending and cracking of expensive aluminum deck castings.
- **Threaded mounting studs:** For easy installation – simply insert the deck-pad into the holes and secure with nuts.
- **Universal:** Purchase a Deck Pad Drill Template (ZOT #620083 – below) and modify your old style decks faster than you can remove old leftover glue residue.

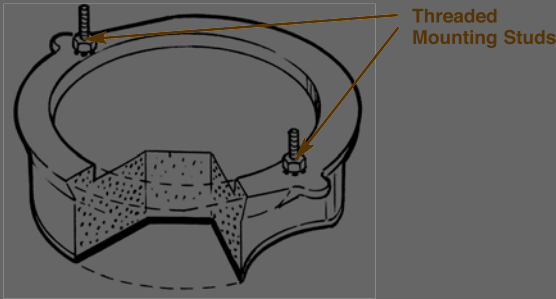

## Dura-Life Deck Pad

#420297 (Package of 10)

“Lasts 3-Times Longer”



**DISCONTINUED**

Dura-Life Deck Pad  
ZOT's Dura-Life Deck Pad features a rugged outer skin for greater durability. Accelerated controlled testing revealed that the average life-cycle of this great new chemically engineered polymer product from ZOT, is “**three times longer**” compared to the original manufacturer's product. ZOT's Dura-Life Deck Pads not only last 3-times longer, they're easier to install.

## Deck Pad Drill Template

#620083

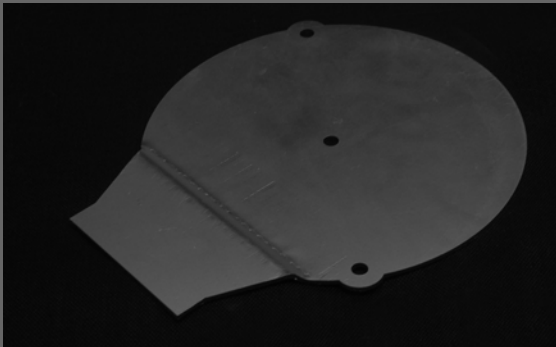

### Features & Benefits

**Easy to Use:** Put an end to messy glue on the deck pads. Convert your older style deck to use current bolt-on type deck pads.

**Save Time:** It's faster to modify your aluminum moving deck than to clean and glue new deck pads in place.

## Standard Urethane Deck Pad

#420294 (Package of 10)

“Twice the Life”

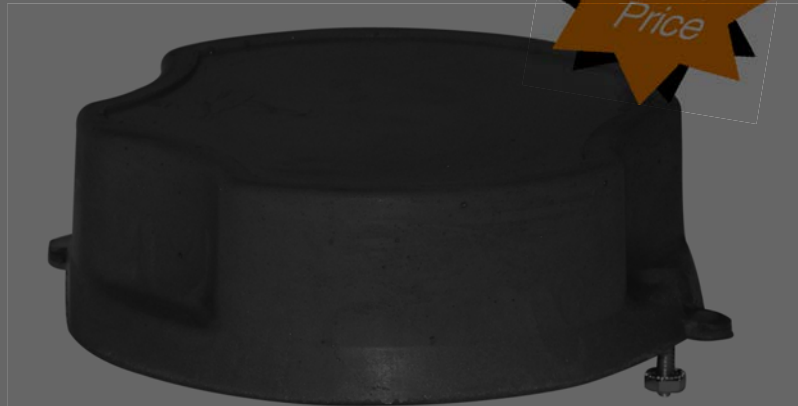

### Standard Deck Pad

Accelerated test results proved that ZOT's Standard Deck Pad will last twice as long as the original manufacturer's product – and they're much easier to install.